

4-H ENTOMOLOGY PROJECT

INTERMEDIATE LEVEL

P. G. Koehler and J. C. Northrop

4HENM11



Acknowledgements

This educational material has been adapted from publications developed by the Entomology Program Development Committee, composed of representatives of the State and Federal Extension Services, the National 4-H Service Committee, and Hercules Inc., national donor. Special acknowledgement is given to cooperators in the State Cooperative Extension Services who have supplied material included in this publication, especially Dr. John Strayer, Professor of Entomology, University of Florida.

P. G. Koehler is a Professor and Extension Entomologist, Entomology and Nematology Department; J. C. Northrop is Associate Professor, Extension 4-H Youth Specialist, 4-H Department; IFAS, University of Florida, Gainesville, 32611.

4-H ENTOMOLOGY PROJECT INTERMEDIATE LEVEL

Collecting and Identifying Insects

NAME _____ DATE _____
ADDRESS _____
NAME OF CLUB _____ COUNTY _____
AGE _____ YEAR IN 4-H CLUB WORK _____
YEAR IN 4-H ENTOMOLOGY PROJECT _____

Welcome to 4-H Entomology

We welcome you to participate in the Intermediate 4-H Entomology Project. The project will introduce you to many new and exciting experiences. As well as being fun, it may help you prepare for the study of insects as your life's work, or help you learn how important insects are in the lives of everyone.

The 4-H project and activities record has been prepared to guide you in this study of insects. Your Extension agent and 4-H leader are advisers to help solve your problems. Obtain and follow their advice closely.

Keep complete and accurate records. This is an important part of the project. You may use more sheets if necessary. Enjoy your project and plan to participate in the advanced 4-H ENTOMOLOGY Project.

Insects are Interesting

There are more different kinds of insects in the world than all other living things put together. Some are so small we need a microscope to see them, and others are several inches in size. Insects are so numerous and widespread they can be studied practically anywhere: in the backyard, the garden, the home, or anywhere man travels in the world.

Entomologists, the scientists who study insects, estimate there are over one-and-one-half million different kinds of insects. Nearly one million kinds have been identified and given names. Insects are so varied in their habits that you can begin an insect study project at any time.

The 4-H Entomology Project is designed so members of all ages can take part. Certain activities can be carried out over several years. They are designed so you can use local resources: if you live in a rural area, study the open fields; if you live in an urban area, put more effort into experiments and library research; and, if a library is not available, spend time collecting and observing insects.

Activities listed in this book are to be used as guides. Keep in mind the Entomology Project fits into many other 4-H projects.

What You Can Do and Learn

Project Goals

1. Learn "What is an insect?"
2. Make or buy:
 - Collecting net
 - Killing jar
 - Insect pins
 - Insect collecting and display box
3. Collect, properly mount and label, identify, and exhibit at least 25 different adult insects representing as many Orders as possible.
4. Protect your collection from scavenger pests.
5. Attend club meetings.
6. Give at least one demonstration or illustrated talk.
7. Keep record book up to date.

Expanded Project Goals

1. Learn to recognize the main body parts of an insect.
2. Make and use:
 - Spreading board
 - Pinning block

3. Collect, properly mount and label, and exhibit at least 50 different adult insects.
4. Identify the Order of all insects collected, and arrange the specimens by Order in your display box.
5. Learn the scientific and common name of at least 5 insects in your collection.
6. Assist leader by:
 - Planning 4-H programs
 - Leading discussions
 - Helping younger members
 - Arranging for guest speakers
 - Finding locations for field trips
7. Give at least one demonstration showing what you have learned.
8. Keep a record of your work.

What is an Insect?

The Animal Kingdom is divided into large groups which have similar characteristics. These groups are called Phyla. Animals with backbones (Vertebrates) and an inner skeleton — such as man, cats, dogs, fish, birds, turtles, snakes, lizards, frogs and toads — belong in the Phylum Chordata.

The Invertebrates have an outer skeleton and no backbone. There are several Phyla in this group, including the Phylum Arthropoda — insects and their relatives. There are many other Phyla, for example: Phylum Mollusca — snails, slugs, clams and oysters; Phylum Annelida — earthworms and leeches; Phylum Nematelminthes — roundworms and nematodes; Phylum Platyhelminthes — flatworms, flukes, and tapeworms; and, Phylum Protozoa — amoeba and paramecium.

The Phylum Arthropoda are animals that:

1. Have a skeleton (hard covering) on the outside of the body. This gives them protection. Most animals have skeletons (bones) inside their bodies. Insects are in the Phylum Arthropoda, and:

1. Have three body regions. The head holds the eyes, mouth parts, and antenna or feelers. The thorax is the middle part with the legs and wings attached. The abdomen is the part behind the thorax, and contains the organs of digestion and reproduction.

2. Have six legs (three pairs). One pair is attached to each segment of the thorax.

3. Have two antennae. The antennae are on the front of the head. They serve as organs of touch and sometimes taste, smell, and hearing. They are often called "feelers."

Parts of an Insect

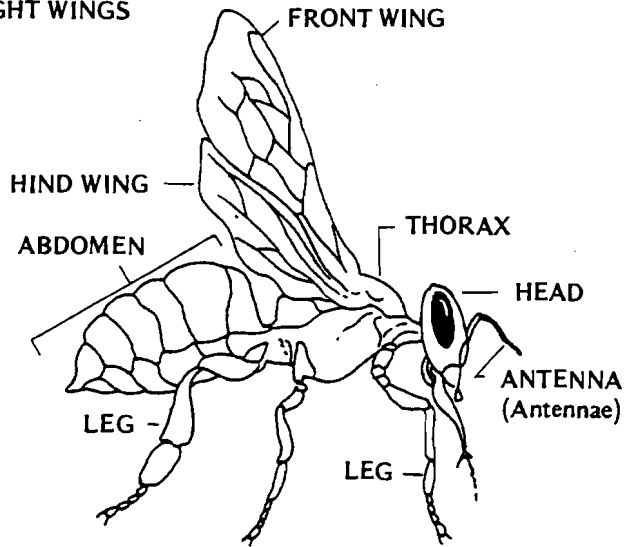
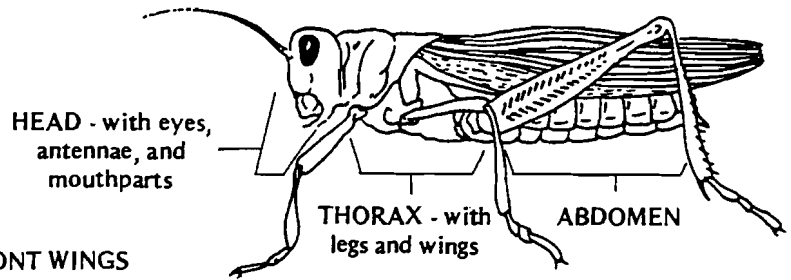
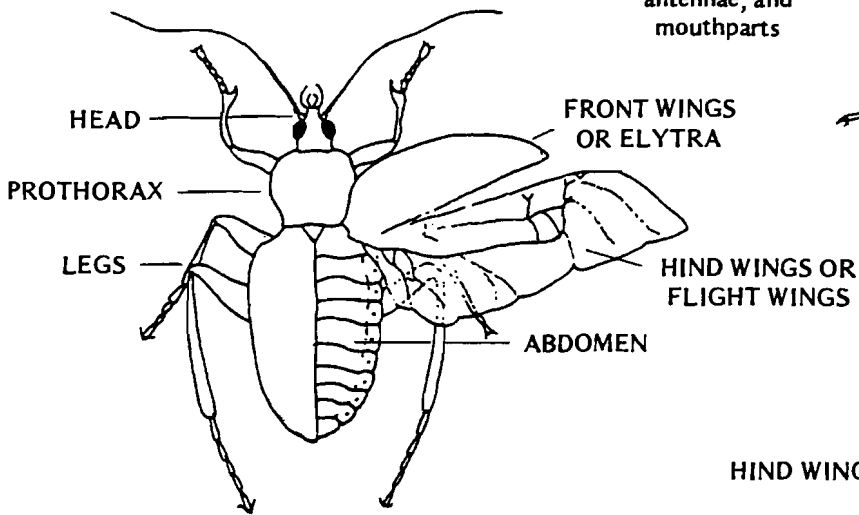

Arthropods

The Phylum ARTHROPODA is further divided into CLASSES. The common classes of Arthropods are:

1. ARACHNIDA (Harvestman, Chiggers, Scorpions, Pseudoscorpions, Spiders, Mites, Ticks)
 - a. The head and thorax are combined into one part (cephalothorax).
 - b. They have no antennae.
 - c. They have four pairs of legs.

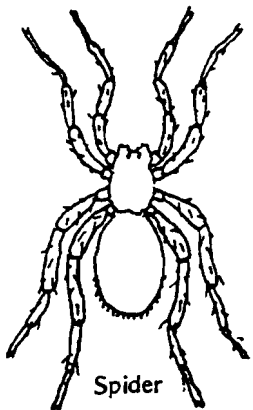

Spider

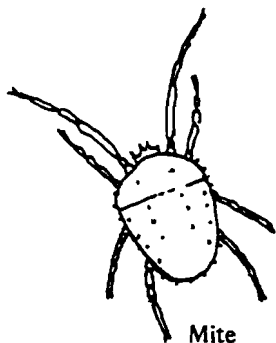

Mite

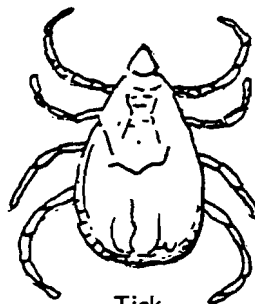

Tick

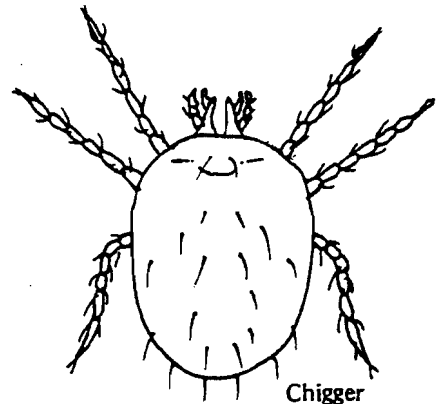

Chigger

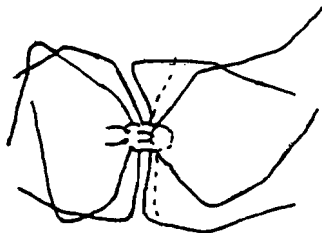

Harvestman

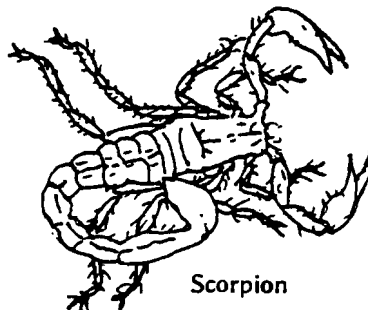

Scorpion

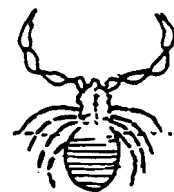

Pseudoscorpion

2. CHILOPODA (Centipedes)

- a. Generally flattened, many segmented, long-bodied animals.
- b. One pair moderately long antennae.
- c. One pair of legs to each body segment.
- d. Usually swift runners, inhabiting the soil.

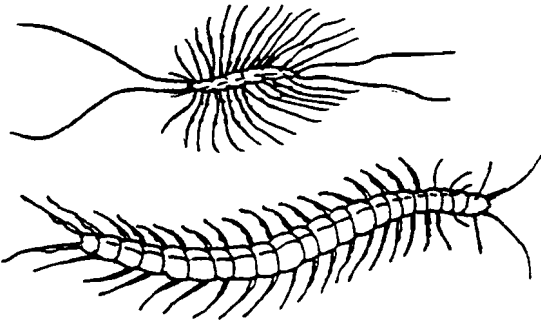

3. CRUSTACEA (Crayfish, Shrimp, Crabs, etc.)

- a. The head and thorax are combined into one part.
- b. Some have two pairs of antenna.
- c. At least five pairs of legs.

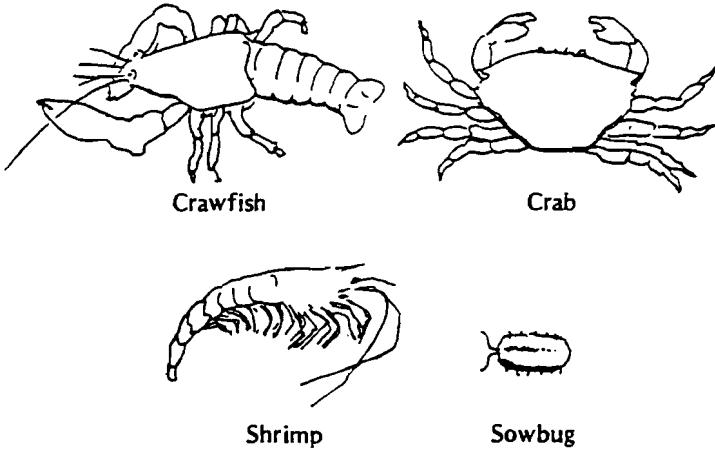

4. DIPLOPODA (Millipedes "thousand-legged worm")

- a. Generally rounded, many segmented, long-bodied animals.
- b. One pair of short antennae.
- c. Two pair of legs to each body segment.
- d. When disturbed, they coil in a characteristic manner.



5. HEXAPODA or INSECTA (Insects)

- a. Body divided into three general regions (head, thorax and abdomen).
- b. Three pairs of legs.
- c. One pair of antennae.
- d. The only Arthropods with wings.

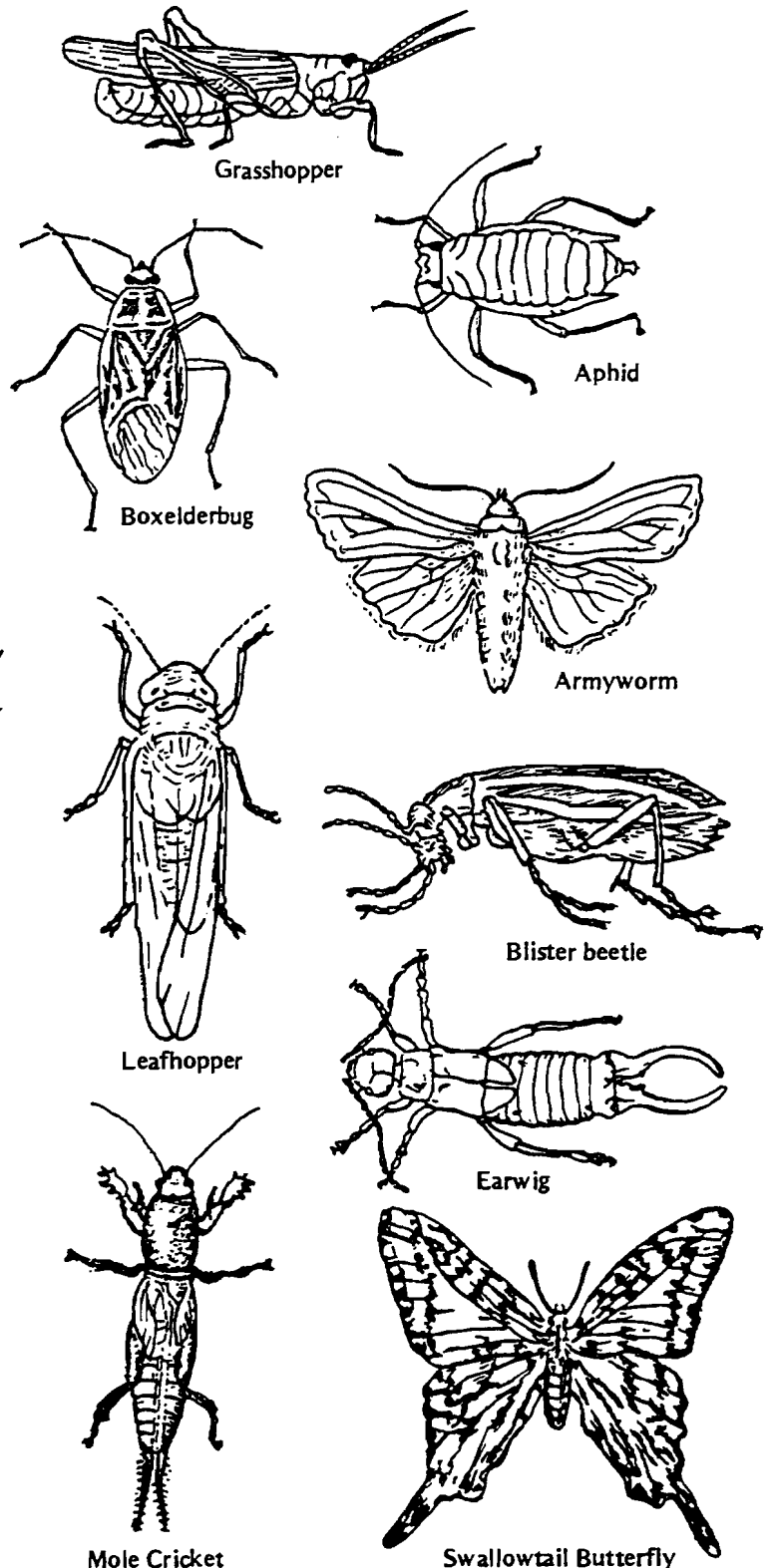

Insect Biology

Where an insect lives, what it eats, what its habits are, and how it reproduces are all questions of insect biology. Most of them can be answered by a study of an insect's life cycle.

The life cycle of an insect is from the egg stage to the reproducing adult. How and what it does during this period is its biology. Metamorphosis is the name given to the change in shape of an insect as it grows. Insects are divided into four groups, depending upon their method of metamorphosis.

In GROUP 1, the insect that comes from the egg looks exactly like it will when grown, except that it will then be larger.

ORDERS

THYSANURA Silverfish
 COLLEMBOLA Springtails
 MALLOPHAGA Biting lice
 ANOPLURA Sucking lice

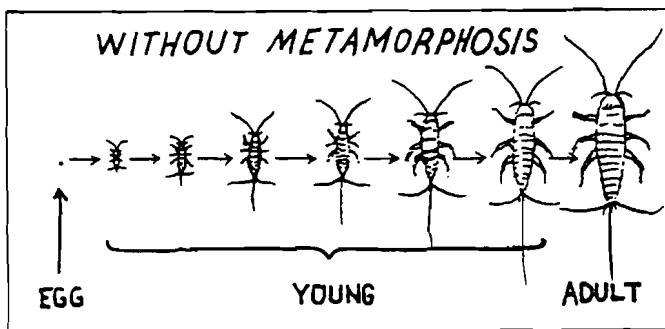

Insects in GROUP 2 change shape gradually. There are three stages of growth: egg, nymph, and adult.

ORDERS

ORTHOPTERA Grasshoppers
 ISOPTERA Termites
 CORRODENTIA Book and bark lice
 THYSANOPTERA Thrips
 HEMIPTERA True bugs
 HOMOPTERA Aphids leafhoppers
 DERMAPTERA Earwigs

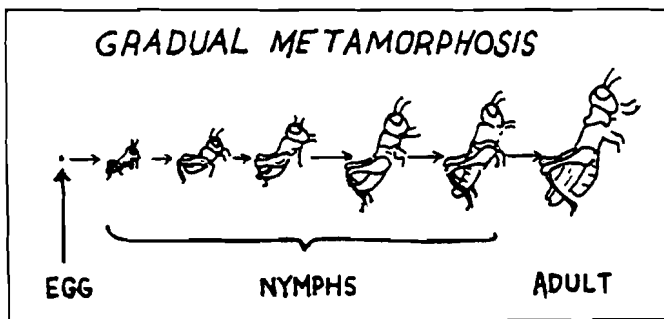

The young insects in GROUP 3 change shape gradually. They do not look like adults until shedding their last skin. Then there is a quick change.

ORDERS

EPEMERIDA Mayflies
 ODONATA Dragonflies
 PLECOPTERA Stoneflies

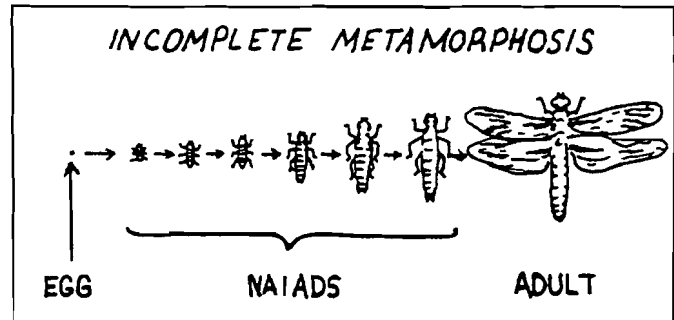

All insects in GROUP 4 go through four stages of growth. None of the young look like the adult. There is a great change in shape when the adult emerges from the pupa stage.

ORDERS

NEUROPTERA Lacewings
 COLEOPTERA Beetles
 STREPSIPTERA Twisted wing parasite
 MECOPTERA Scorpionflies
 TRICHOPTERA Caddisflies
 LEPIDOPTERA Moths, butterflies
 DIPTERA Flies
 SIPHONAPTERA Fleas
 HYMENOPTERA Bees, wasps

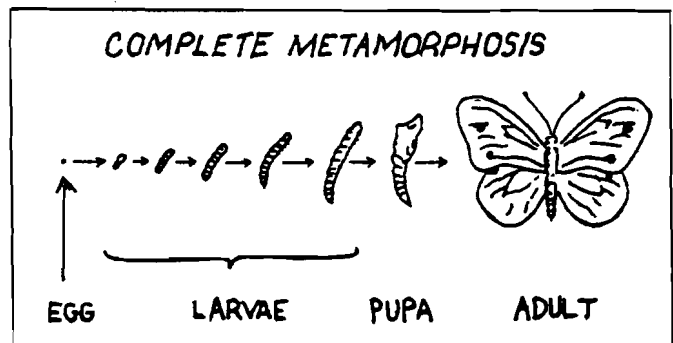

Where to Look for Insects

- In the air for flying insects on warm days from early spring to late fall.



- On (or in) fresh or decaying fruit.



- On a wide variety of vegetation, both day and night.

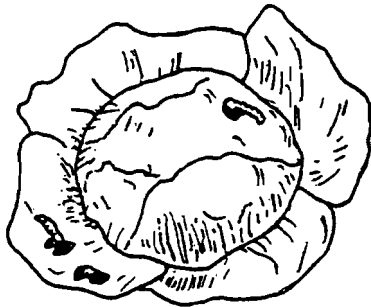

- On domestic animals for parasitic insects, such as fleas and lice.



- Around street lights, porch lights, and study lamps.



- Along the edges of rivers, streams, lakes or ponds and in the water.

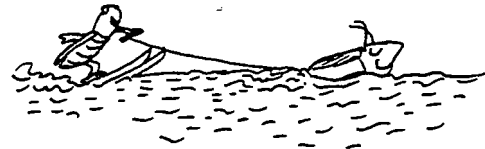

- In woodpiles, especially in spring and early summer.

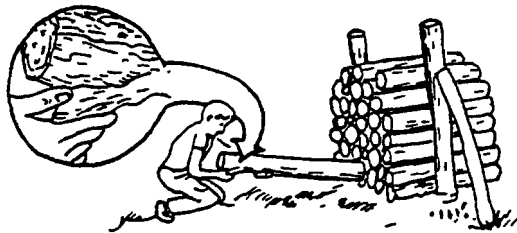

- In buildings-windows, flour bins, cereal packages, closets or boxes where clothing and old papers are stored.



- In the soil.



Collecting Net

Materials Needed

- Small wood handle, 3 feet long (broom handle or dowel).
- About 5 feet of heavy wire (No. 9) for hoop.
- Piece of unbleached muslin or netting, 3 x 5 feet.
- Soft wire, heavy string or metal sleeve for net handle to hold hoop wire.
- Needle and heavy thread.

Procedure

1. Bend heavy wire into a circle (about 12 inches) to form a hoop. Make arms for fitting in net handle by bending wire $2\frac{1}{2}$ inches and $3\frac{1}{2}$ inches.
2. Bore holes in the net handle for the arm hooks. If you want a smooth fit, groove handle as shown.
3. See "Net Bag Construction" for instructions to make a bag.
4. Thread the wire hoop through the hem of the bag and insert wire arms into the handle. Slip the metal sleeve over the net handle to hold the wire arms in place. If preferred, the hoop arms may be attached to the net handle by wrapping with soft wire or heavy string.

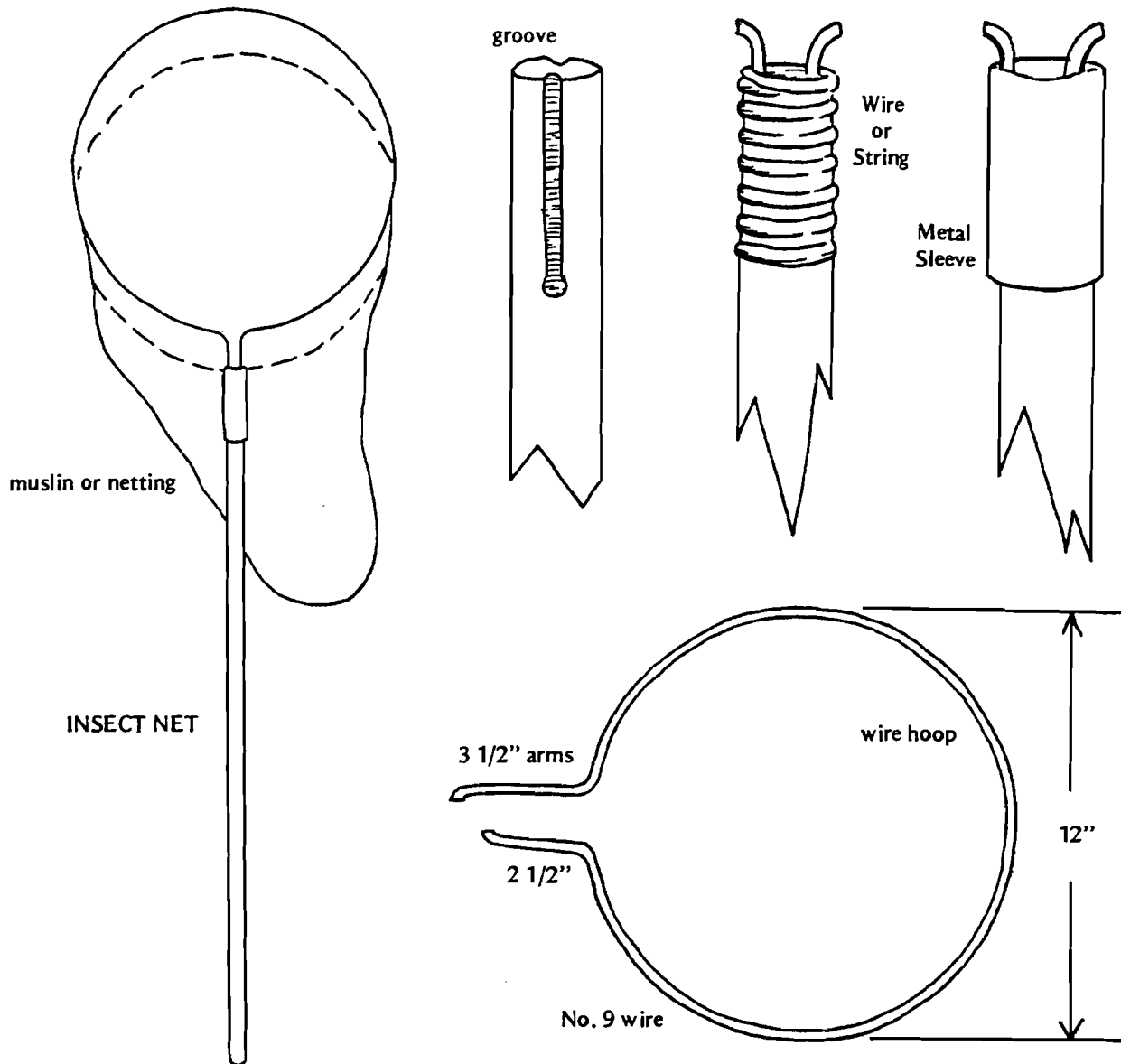

Net Bag Construction

To construct the net bag, lay a 20 x 30-inch piece of net material (muslin or netting) on another piece of material that is the same size (Fig. A), and fold them to make the folded material 10 x 30 inches (Fig. B). Cut the material from the bottom folded corner diagonally up and across to a point 10 inches below the top unfolded corner (Fig. C). The net bag after cutting will be in two, roughly triangular pieces (Fig. D).

Stitch the two halves of the net together, making the seam about 1/2 inch from the cut edge and leave 10 inches free on one side at the top where the net hoop will be inserted (Fig. E). Turn the cut edges inside and stitch the seam down flat (flat felled seam).

To make a loop for the wire hoop, fold the top edge down 5 inches (Fig. F). Then turn the folded edge down 2 1/2 inches and stitch a hem (Fig. G). If you desire to reinforce the hem of aerial nets made of netting, you can make only one fold and cover the fold with a strip of muslin 5 x 40 inches. Then fold again and stitch. The muslin will protect the netting around the wire hoop.

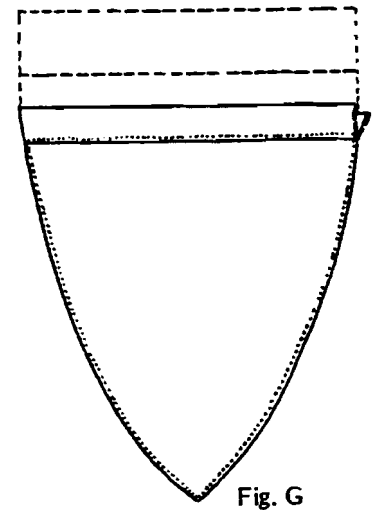
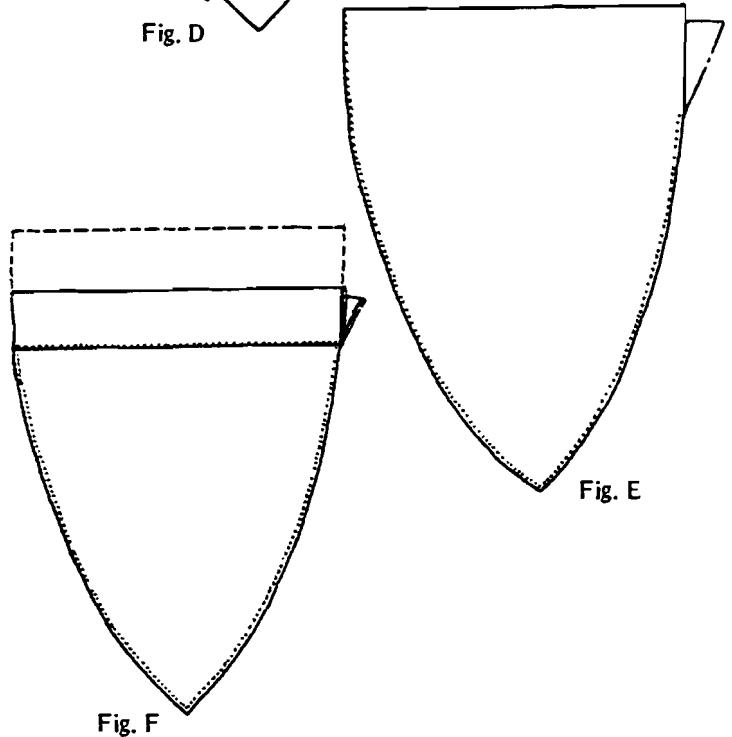
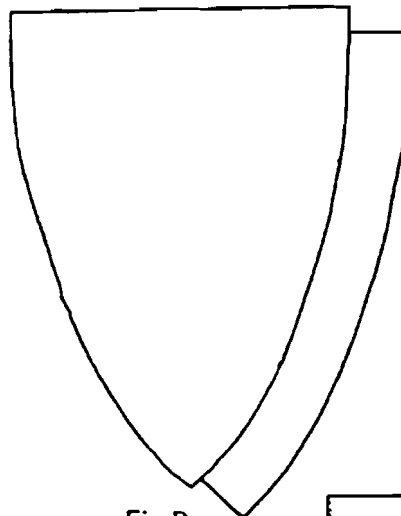
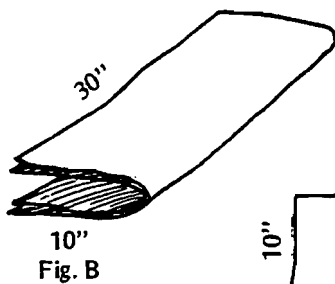
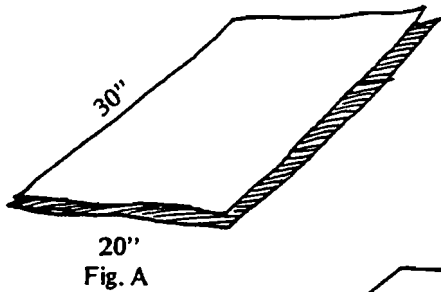

How to Collect Insects with a Net

A special technique should be followed in netting certain insects, especially stinging and "biting" insects like wasps, bees, hornets, assassin bugs, and tiger beetles. Sweep the insect into the net, and with a quick jerk force it to the bottom of the bag. Then grasp one hand around the bag just above the captured insect. Insert the end of the bag along with the captured insect into the killing jar. Place the jar lid over the mouth of the jar as tightly as possible, and hold it for 30 to 60 seconds until the insect becomes motionless. Remove the end of the net from the killing jar and put the stunned insect back in the killing jar. Always stand sideways to the wind while opening and handling your killing jar.

Collecting butterflies and moths, without damaging the specimen, requires a special technique and care in handling the net. To prevent butterflies or moths from escaping after being netted, whip the net so the insect goes to the bottom of the bag. Quickly flip the bag bottom making it rest across the wire hoop. Then squeeze the thorax of the butterfly between your thumb and forefinger. This will stun the insect and prevent it from beating the scales off its wings when it is dropped in the killing jar.

Many kinds of insects "play possum" and become inactive when disturbed. To catch these insects, hold your net under plants and shake the insects off into the net. Transfer them into the killing jar.

Make an Insect Killing Jar

Any substance poisonous enough to kill insects can injure you if not handled with proper care and caution. Study the properties and hazards of various chemicals available for use as killing agents in insect killing jars.

Killing agents commonly used are carbon tetrachloride and ethyl acetate. Fingernail polish remover, which contains acetone, is a good killing agent. Your local 4-H leader and County Extension office can obtain information on what killing agents to use from the State Entomology office. Most killing agents can be obtained through your local pharmacist. Use proper safety procedures when handling killing agents.

Preparing the Killing Jar

The jar size depends on the size and kind of insects collected. For butterflies and moths, a wide-mouth, pint mayonnaise or pickle jar with a screw cap is satisfactory. A smaller, wide-mouth jar can be used

for collecting beetles, bugs, and most small insects.

Place in the bottom of the jar some chips of rubber, a piece of sponge, celotex, cotton, or similar absorbent material to absorb the killing agent. Fill the jar $\frac{3}{4}$ of an inch to 1 inch with the absorbent materials. Cover the material with a piece of corrugated cardboard that fits snugly against the inside walls of the jar. This will hold the absorbent material in place and prevent the insects from getting tangled or wet. You are now ready to add the killing agent (charge the jar).

Plaster of paris can also be used as an absorbent material. Mix 8 heaping teaspoons of plaster of paris with 5 teaspoons of water in a mixing cup. This should make a paste about as thick as a frosted malt drink. Stir the mixture until smooth. Pour or spoon the mixture into a pint killing jar. Tap the killing jar against the ground so the plaster of paris has a smooth surface. With the cap off the jar, let the plaster of paris set for one day. When the plaster of paris is thoroughly set, pour as much killing agent into the killing jar as will be absorbed by the plaster of paris.

Pour out any excess liquid that is not absorbed. Cover the material with a piece of corrugated cardboard that fits snugly against the inside walls of the jar. Cap the killing jar immediately.

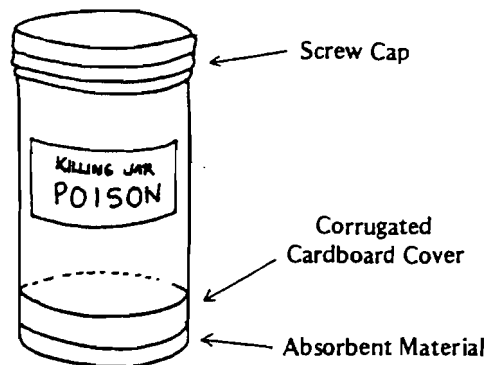

Charging the Killing Jar

Killing agents are poisonous to swallow or breathe, and some can be absorbed through the skin. To reduce danger while charging the killing jar, go outdoors and stand sideways to the wind so fumes will blow past you. Remove the corrugated cardboard cover. Use a medicine dropper to suck up the chemical and squirt it onto the absorbent filler. Repeat until the absorbent material is saturated, taking care not to get the liquid on your hands. Wear rubber gloves, if available. After charging the killing jar, replace the corrugated cardboard cover over the saturated absorbent material and screw the cap on tightly. Wash your hands thoroughly and clean the medicine dropper immediately with soap and water.

Labeling the Killing Jar

Paste or stick a "Poison" label on the killing jar where it will be easily seen. Keep the killing jar closed when not in use. Do not breathe the fumes or let anyone smell the killing jar.

Recharging the Killing Jar

When it is necessary to recharge the killing jar, follow the same procedure as for charging it. Do the job outdoors, use a medicine dropper for transferring the killing agent, and wash your hands and clean the dropper with soap and water as soon as you are finished.

Protect the Killing Jar

Prevent breaking the insect killing jar by wrapping several layers of masking tape around its base. Such padding will prevent shattering, if accidentally dropped.

Read and follow the label instructions on the killing agent container. Store the bottle out of the reach of small children.

Insect Killing Jar



POISON



DANGER

MAY BE FATAL IF INHALED OR SWALLOWED

Remember, choose a jar suitable for the purpose, charge it carefully outdoors, label it properly, and protect it from breakage. Be sure to wash your hands after each handling; wear rubber gloves, if possible. Do not breathe the fumes or get the liquid on your skin.

Pinning Insects

Each group of insects has its own characteristics as to shape and body balance, making it necessary to correctly place the pin in the insect. Pin insects shortly after they are killed, before they become brittle and break.

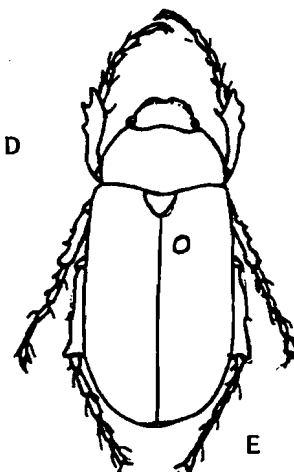
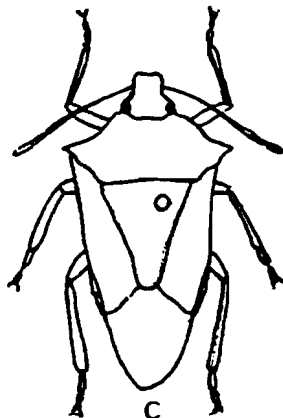
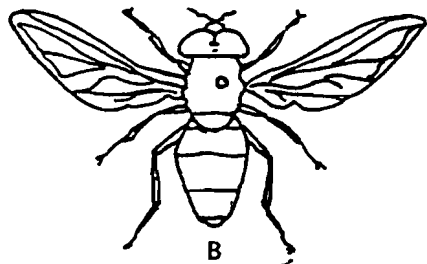
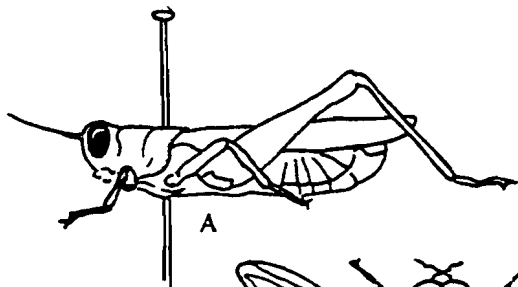

Make a Pinning Block

Medium and larger-sized insects should be pinned vertically through the body, using the pinning block to set the height of the insect on the pin. A simple temporary pinning block may be made of corrugated cardboard. A more permanent type of pinning block can be made of wood.

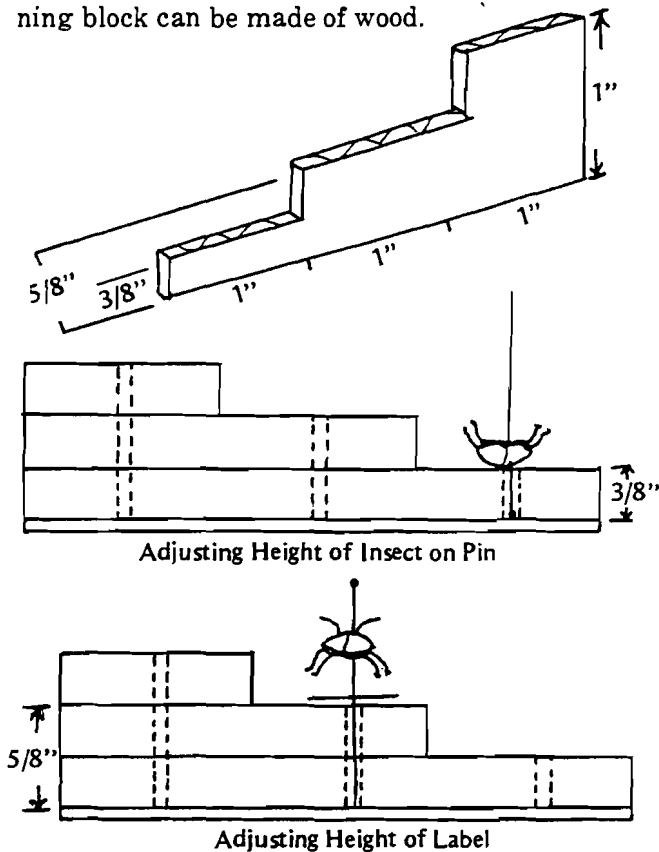

How to Card Point Small Insects

1. Select some heavy paper, such as filing cards, for cutting out card points.
2. Cut the points in the shape shown. The points should be about 3/8-inch long.

A card point

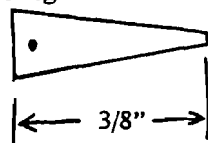

3. Put a pin through the base of the card point and push it up on the pin to about 1/4 inch from the top of the pin. Use a pinning block to get the points to a uniform height.



4. With a pair of tweezers, bend the tip of the card point down.
5. Put a tiny drop of glue on the bend-down part of the card point, and press it gently to the underneath right side of the insect. Clear fingernail polish or any clear drying glue may be used. Be sure the insect is "square with the world" and not at an angle. This takes practice!

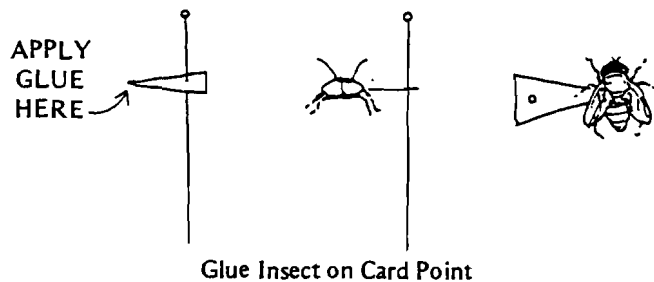

Block Spreading Board

Materials Needed

- Block styrofoam approximately 6 x 6 x 2 inches.
- Pocket knife.

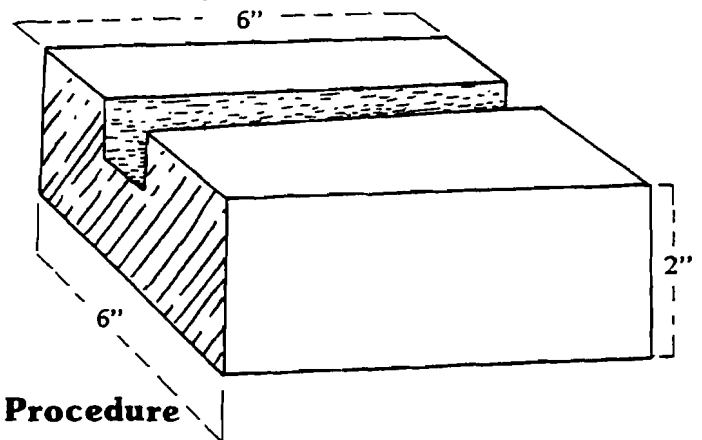

Procedure

Cut a wide groove across the block. The groove should be about 1/4-inch wide and 1/2-inch deep. This makes a slot for the body of the insect to rest in when spreading. You may wish to make three or four of these blocks (some with broad and some with narrow slots) for spreading small or large butterflies or moths.

Spreading Butterfly Wings

1. Put an insect pin through the center of the thorax of a freshly killed butterfly. Approximately 1/4-inch of the pin should be exposed above the thorax. Make sure the insect does not tip from side to side or from front to back on the pin. Occasionally an insect will dry out before it can be pinned. When this happens it is necessary to relax the insect before pinning it. This can be accomplished by using a relaxing jar or can. Select a wide-mouth jar or can that has a tight-fitting cover and place one or two inches of sand in the bottom. Saturate the sand with water. (Be sure to add a few pinches of naphthalene flakes to the water to retard growth of mold.) Cover the sand with a piece or two of heavy cardboard cut to fit the container. Do not let the specimens come in contact with the water and do not leave specimens in the container too long. Usually 1 to 3 days is sufficient. Do not let the "relaxer" get too warm or it will "sweat" on the inside.

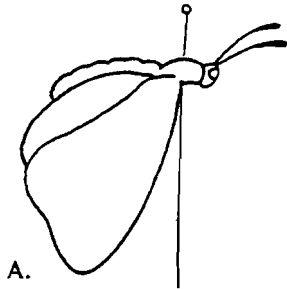

2. Push the pin straight down in the center of the slot of your pinning board until the outstretched wings are just level with the surface of the pinning board.

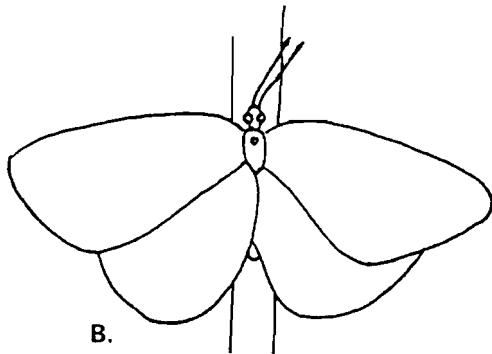

3. Insert an insect pin lightly in each front wing near the front margin and just behind one of the heavy wing veins. Move the front wings forward gently until the hind margins of the front wings are in a straight line, at right angles to the body.

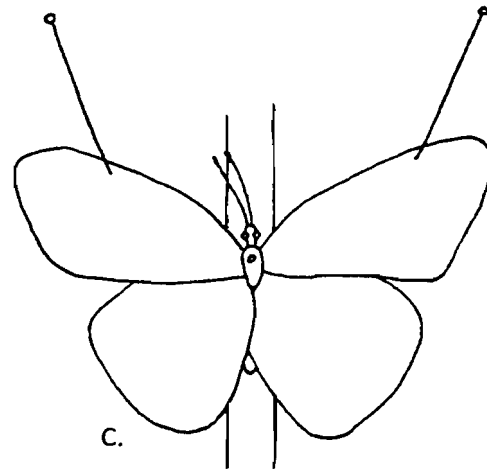

4. With a pin placed behind a heavy vein in the hind wing, move each hind wing forward until the gap between the front wing and hind wing is closed to just a notch, as shown in the right side of D.

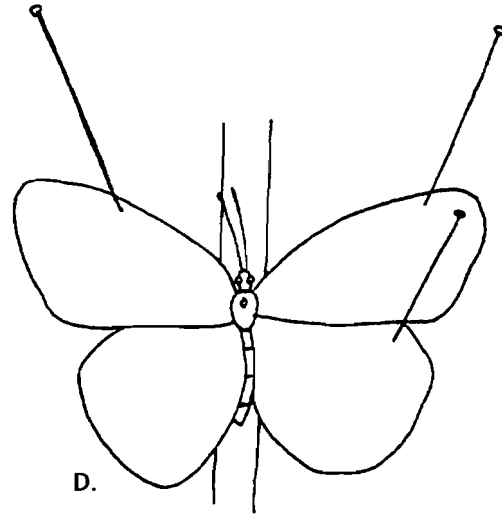

5. Cut some narrow strips of paper and lay them over the wings. Pin them in place as shown. Remove the other pins that are through the wings. The pins holding the paper strips in place should be close to them in order to keep enough pressure on the wings to prevent their slipping out of place. Some entomologists use transparent paper so they can see if the wings have slipped out of place while the specimen is drying. Too thin a paper will not put enough pressure on the wings. If the abdomen tends to sag, it can be propped up with pins until it dries. Pins can also be used to keep the antennae in place while the specimen dries. Depending on the moisture in the air, the specimen should remain on the board from four to eight days.

Note: As you gain more practice with spreading butterflies, you will want to use a method that does not puncture the wings with pins. This method is shown in some entomology books.

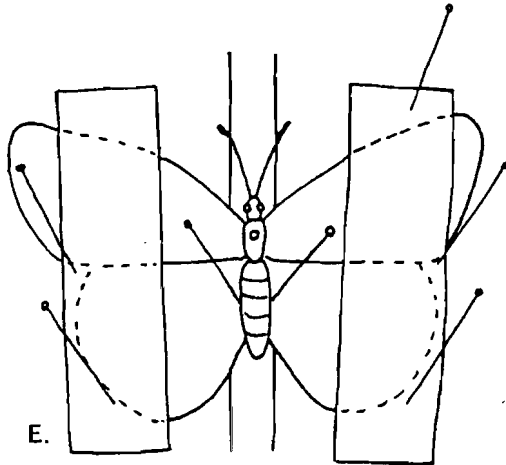

Labeling Insects

Labels should be printed on heavy paper, such as for file cards. The most important label is the one that tells where, when, and by whom the insect was collected. Every pinned insect should have this label. Remember, a specimen without a date, locality, and collector label is practically worthless. The "where found" and "common name" labels may also be added if you know this information. Place labels at the desired height on the pin by means of a pinning block.

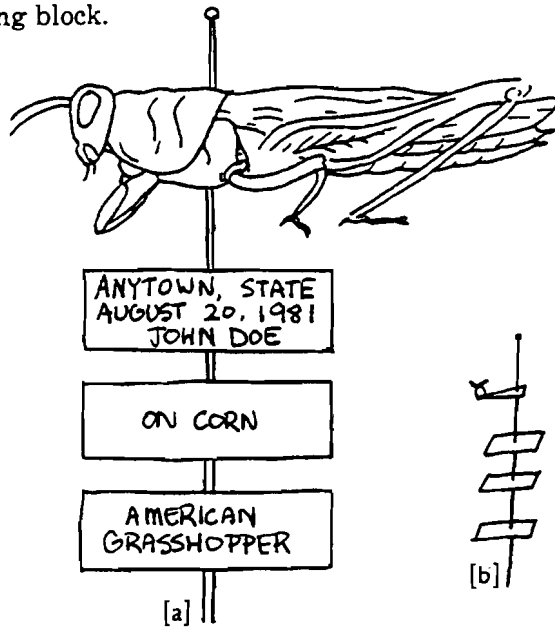

[a] Showing information on each label.

[b] Showing proper arrangement on pin.

Make a Collection Box

Materials

- Cigar box, 2 x 6 x 8 inches or any other similar sized sturdy box.
- Piece of corrugated cardboard, soft fiberboard or styrofoam.
- Glue.
- Moth crystals — to keep pests out of collections.
- Pill box or safety match box — to hold moth crystals.
- Insect pins of No. 2 or No. 3 size. Your 4-H leader may obtain these from the Entomology Department at the University of Florida.
- Insect labels.

Procedure

1. Cut the cardboard to fit bottom of box.
2. Smear glue on the bottom of the box and insert cardboard.

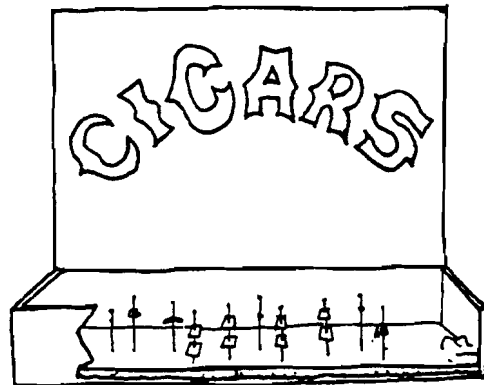
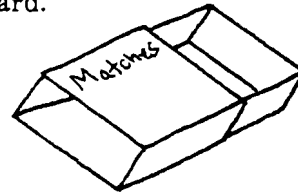

3. Line box with white paper.
4. Fill match box or small pill box with moth crystals.
5. If the pill box is air tight, punch some holes in the lid.
6. Pin the box in a corner of the cigar box.

Identifying Your Insects

Each insect you collect will belong in a particular order. This is the system used in grouping insects. Check a high school biology text or similar reference for the description and the illustrations of the Orders. Place your insects in the Orders in which they belong.

Project Accomplishments

If you have difficulty or need help in completing this project, ask your parents to help you. Your local 4-H leader and county Extension agent can also give you valuable help.

1. Answer questions completely.

- Did you make a killing jar? _____
- Did you make a collection box? _____
- Did you make an insect collecting net? _____
- Did you make a spreading board? _____
- Did you make a pinning block? _____
- How many different insect species did you collect and mount?

- How many different Orders do you have in your collection?

2. List the things you have learned in your project, and any interesting experiences.

a. List your goals for your entomology project this year. _____

b. List new things you learned in this project. _____

c. List your most important accomplishments in your project this year. _____

d. List demonstrations, appearances, exhibits, articles written, tours, workshops, camps and field trips that you participated in through this project. _____

e. List awards and recognitions received in this project. _____

f. List your leadership participation in this project. _____

g. List what your club or group did in this project. _____

h. List your citizenship and community service experiences in this project. _____

i. List your experiences in other 4-H activities. _____

j. List 4-H leadership experiences. _____

k. List 4-H citizenship and community service experiences. _____

l. List your non-4-H experiences in school, church, and community. _____

LEADER _____

COUNTY EXTENSION AGENT _____

